



REALTEK

RTS5130

USB 2.0 Card Reader Controller

DATASHEET

**Doc Rev. 0.9
17 Apr. 2007**



REALTEK

Realtek Semiconductor Corp.

No. 2, Innovation Road II, Hsinchu Science Park, Hsinchu 300, Taiwan

Tel.: +886-3-578-0211. Fax: +886-3-577-6047

www.realtek.com.tw

TRADEMARKS

Realtek is a trademark of Realtek Semiconductor Corporation. All other names mentioned in this document are trademarks/registered trademarks of their respective owners.

Realtek provides this document “as is”, without warranty of any kind, neither expressed nor implied, including, but not limited to the particular purpose. Realtek may make improvements and/or changes in this manual or in the product(s) and/or the program(s) described in this manual at any time. This document could include technical inaccuracies or typographical errors.

Revision History

Revision	Description	Page	Date
0.90	Preliminary release		2007/04/17

Table of Contents

1. GENERAL DESCRIPTION	1
2. FEATURES	1
3. BLOCK DIAGRAM.....	3
4. PIN DESCRIPTIONS	4
4.1 USB Transceiver.....	4
4.2 System Interface	4
4.3 EEPROM Interface	4
4.4 CompactFlash / MicroDrive Interface	5
4.6 SmartMedia / xD-Picture Card Interface.....	5
4.7 Secure Digital / MultiMediaCard Interface	6
4.8 Memory Stick PRO / Memory Stick Interface.....	6
4.9 Power and Ground.....	6
4.10 I/O Type Description	7
5. PIN ASSIGNMENT	8
6. CARD POWER SWITCH	9
<i>RTS5130 integrates all regulators and MOSFET components to supply and switch power for cards</i>	9
7. ELECTRICAL CHARACTERISTICS	10
7.1 Absolute Maximum Ratings.....	10
7.2 DC Characteristics.....	10
8. PACKAGE DIMENSIONS	11
<i>LQFP-100</i>	11
9. ORDERING INFORMATION.....	13

1. General Description

The RTS5130 is an ultimate throughput USB 2.0 compliant card reader controller that integrates USB 2.0 Transceiver, MCU, SIE, regulators and memory card access units into a single chip. The RTS5130 can support CompactFlash™, Micro Drive, Smart Media Card™, Memory Stick™, Memory Stick Pro™, Secure Digital™, Multi-Media Card™ and xD-Picture Card™. The RTS5130 also reserves lots of access control flexibility to achieve the best compatibility over miscellaneous memory cards.

The RTS5130 integrates 5V-to-3.3V and 3.3V-to-1.8V regulators, clock generation circuitry and four MOSFET components, and could dramatically reduce the system BOM cost.

2. Features

- Compliant with Universal Serial Bus Specification Revision 2.0
- Compliant with USB Mass Storage Class Bulk only Transport Specification Rev. 1.0
- Supports High-speed (480Mbps) and Full-speed (12Mbps) Data Transfer
- Supports USB bus power operation
- Supports Control, Bulk and Interrupt USB data pipes
- Supports the following memory card interfaces:
 - CompactFlash™ (CF), MicroDrive
 - SmartMedia™ (SM)
 - Secure Digital™ (SD), MultiMediaCard™ (MMC), Mini-SD, Micro-SD (T-flash), RS-MMC, Mobile-MMC and MMC-micro
 - Memory Stick™ (MS), Memory Stick PRO™ (MS-PRO), MS Duo, MS-PRO Duo and Micro-MS (M2)
 - xD-Picture Card™ (xD) including Type M and Type H
- Supports hardware ECC (Error Correction Code) function
- Supports hardware CRC (Cyclic Redundancy Check) function
- Programmable clock rate for flash memory card interfaces
- Supports CF **v4.0** with PIO mode 6 and **Ultra DMA** mode
- Supports MS-PRO **v1.02**
- Supports MS **v1.43**
- Supports SD version **2.0**
- Support MMC version **4.2** with 4-bit data bus

- Supports xD **v1.2**
- Support SM **2003**
- Integrated Fast 8051 microprocessor
- Supports firmware upgrade via USB port
- External serial EEPROM interface
- 12MHz crystal oscillator with integrated PLL
- On chip 5V to 3.3V regulator
- On chip 3.3V to 1.8V regulator
- On chip 4 MOSFET components for direct power control of all types memory cards
- Supports Spread Spectrum Clock (SSC) for SD/MMC and MSPRO/MS to reduce EMI effect
- Supports USB remote wake-up ability with memory card inserted and removal operation
- 100-pin LQFP package

3. Block Diagram

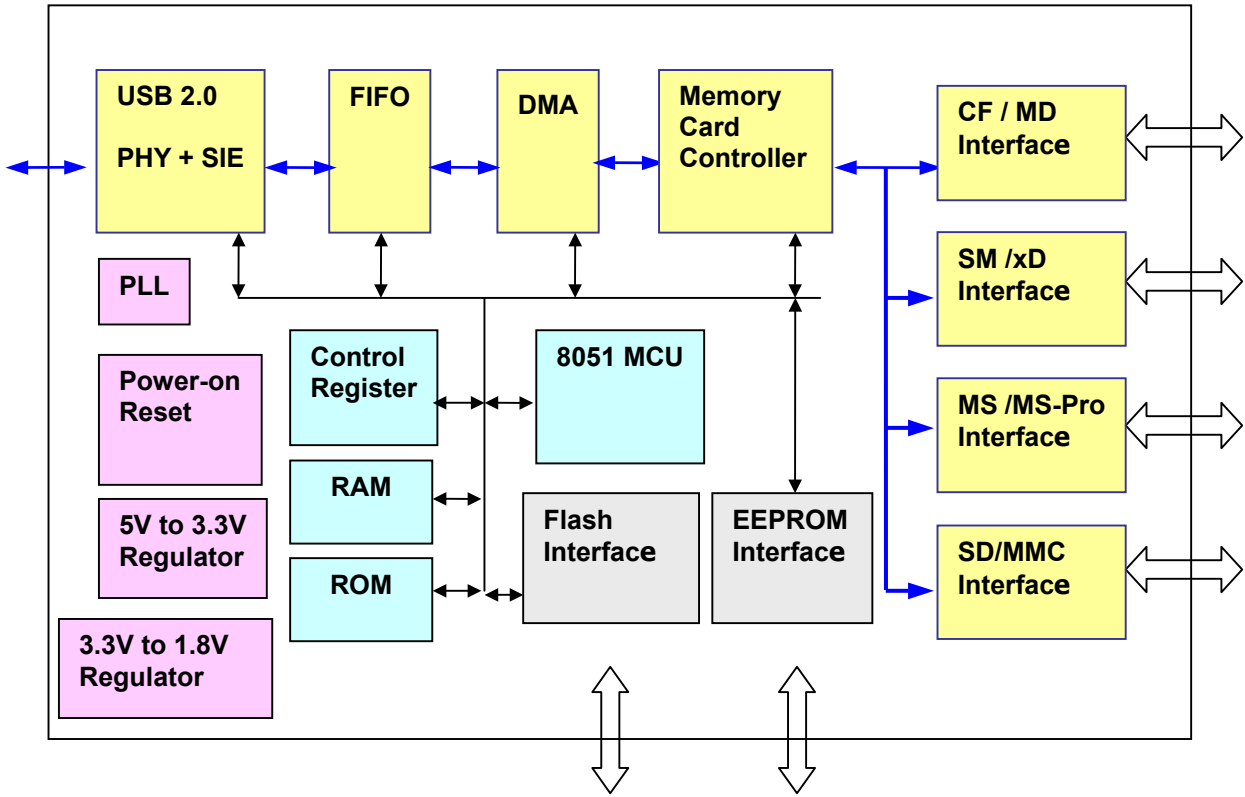

RTS5130 Block Diagram

4. Pin Descriptions

4.1 USB Transceiver

Name	Type	I/O Type	Pin No.	Description
DP	I/O	IO-U	13	USB D+ signal
DM	I/O	IO-U	12	USB D- signal
RREF	N/A	IO-U	10	Connect external resistor (6.25K ± 1%) to Analog Ground AGND

4.2 System Interface

Name	Type	I/O Type	Pin No.	Description
XTLI	I	CLK	7	Crystal oscillator input (12 MHz). Also can be used as external clock input
XTLO	O	CLK	8	Crystal oscillator output (12 MHz)
RST#	I	IOSH	98	System reset
MODE_SEL	I	I	5	Used for Mode selection
GPIO0	I/O	IOH	64	General purpose input/output with interrupt ability
GPIO1	I/O	IOH	2	General purpose input/output with interrupt ability
GPIO2	I/O	IOH	3	General purpose input/output with interrupt ability
GPIO3	I/O	IOH	4	General purpose input/output
GPIO4	I/O	IOH	25	General purpose input/output
GPIO5	I/O	IOH	75	General purpose input/output

4.3 EEPROM Interface

Name	Type	I/O Type	Pin No.	Description
EECS	O	O	21	Chip select to EEPROM (93C46)
EESK	O	O	22	Clock signal to EEPROM
EEDI	I	IL	23	Serial data in from EEPROM
EEDO	O	O	91	Serial data out to EEPROM (Same as XD_WP#)

4.4 CompactFlash / MicroDrive Interface

Name	Type	I/O Type	Pin No.	Description
CF_CD#	I	IH	24	CF Card detect
CF_A [2:0]	O	O	27, 90, 88	Address bus for card task file registers
CF_D[15:0]	I/O	IOL	34, 55, 57, 59, 61, 82, 83, 85, 54, 56, 58, 60, 62, 84, 86, 87	CF DATA bus
CF_CS0#	O	O	33	Chip select for task file register
CF_CS1#	O	O	32	Chip select for Alternate Status Register and Device Control Register
CF_RST#	O	O	29	Active low hardware reset signal from the host
CF_IORD#	O	O	31	I/O read strobe
CF_IOWR#	O	O	30	I/O write strobe
DMACK#	O	O	89	A DMA Acknowledge signal that is asserted by the host in response to DMARQ to initiate DMA transfers.
DMARQ	I	IL	26	A DMA Request that is used for DMA data transfers between host and card
CF_IORDY	I	IH	28	Ready pin

4.6 SmartMedia / xD-Picture Card Interface

Name	Type	I/O Type	Pin No.	Description
SM_CD#	I	IH	35	SM Card detect
XD_CD#	I	IH	67	xD Card detect
SM_WPM#	I	H	63	SM Card Mechanical Write Protect
XD_D[7:0]	I/O	IOL	38, 40, 52, 53, 51, 39, 37, 36	Multiplexed address, command and data bus for xD/SM
XD_ALE	O	O	95	Address latch enable
XD_CLE	O	O	97	Command latch enable
XD_CE#	O	O	96	Card enable
XD_RE#	O	O	94	Read enable
XD_WE#	O	O	93	Write enable
XD_RDY	I	I	92	Ready/Busy (Internal Pull up 2K or Pull down 200K)

4.7 Secure Digital / MultiMediaCard Interface

Name	Type	I/O Type	Pin No.	Description
SD_DAT [3:0]	I/O	IOH	80, 81, 70, 71	SD/MMC data signals
SD_CMD	I/O	IOH	78	Serial protocol command and response signal
SD_CLK	O	O	74	Serial protocol clock signal
SD_WP	I	I	68	Write Protect switch signal
SD_CD#	I	I	69	SD/MMC Card detect

4.8 Memory Stick PRO / Memory Stick Interface

Name	Type	I/O Type	Pin No.	Description
MS_INS#	I	I	45	Card Detection
MS_BS	O	O	41	Bus state
MS_D[3:0]	I/O	IOL	46,44,42,43	Memory Stick™ / Memory Stick PRO™ data signals
MS_CLK	O	O	47	MS Clock signal

4.9 Power and Ground

Name	Type	I/O Type	Pin No.	Description
AV33	Power	Power	11	3.3V Analog power
AG33	Power	Ground	14	Analog ground (3.3V)
AV_PLL	Power	Power	9	Power for PLL
AG_PLL	Power	Ground	6	Analog ground (PLL)
VREG	Power	Power	18	Regulated supply voltage (1.8V ±10%) from internal 3.3V to 1.8V regulator; supplies internal digital circuits. An external capacitance should be connected
5V_IN	Power	Power	16	5V input to internal regulator (5V to 3V3)
D3V3_OUT	Power	Power	19	3.3V output from internal regulator (5V to 3V3) as digital power
A3V3_OUT	Power	Power	15	3.3V output from internal regulator (5V to 3V3) as analog power
D3V3	Power	Power	49,66,99	3.3V digital power
MS_3V3	Power	Power	50	3.3V power to MS/MS-Pro
SD_3V3	Power	Power	76	3.3V power to SD/MMC
XD_3V3	Power	Power	1	3.3V power to SM/xD
CF_3V3	Power	Power	17	3.3V power to CF
DGND	Power	Ground	20,48,65, 100	Digital ground

4.10 I/O Type Description

I/O Type	Description
O	Output
I	Input
IH	Input with internal pull-high 200K
IL	Input with internal pull-down 200K
IO	Input / Output
IOL	Input / Output with internal pull-down 200K
IOH80	Input / Output with internal pull-up 80K
IOH	Input / Output with internal pull-up 200K
IOSH	Input / Output with Schmitt trigger
IO-U	USB related IO
CLK	Clock related IO

6. Card Power Switch

RTS5130 integrates all regulators and MOSFET components to supply and switch power for cards.

1. The maximum range of the PMOS output current

- CF card: 500mA
- SM/xD card: 120mA
- MS/MSPRO card: 250mA
- SD/MMC card: 220mA

2. The maximum range of the 5V regulator is 550mA

7. Electrical Characteristics

7.1 Absolute Maximum Ratings

Parameter	Rating
Supply Voltage	-0.5V to +5.5V electrical characteristics
Operating Temperature	0°C to +70°C
Latchup Current	350 mA
Electrostatic Discharge	5 kV (Use RTS5130 LQFP-100)

7.2 DC Characteristics

Symbol	Description	Conditions	Min.	Typ.	Max.	Unit
V _{DD}	Supply Voltage		4.5	5	5.5	V
V _{IH}	Input Voltage High		2		3.6	V
V _{IL}	Input Voltage Low		-0.5		0.8	V
V _{OH}	Output Voltage High		2.4			V
V _{OL}	Output Voltage Low				0.4	V
C _{in}	Input Pin Capacitance				10	pF
I _{DD}	Supply Current	8051 is running @ 24MHz		76		mA
I _{SUS}	Suspend Current	D+ 1.5KΩ resistor is included		330		uA
P _T	Total Power Dissipation			380		mW

8. Package Dimensions

LQFP-100

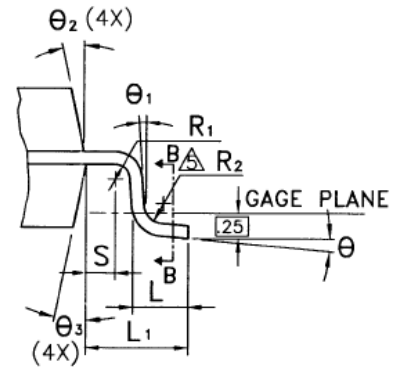
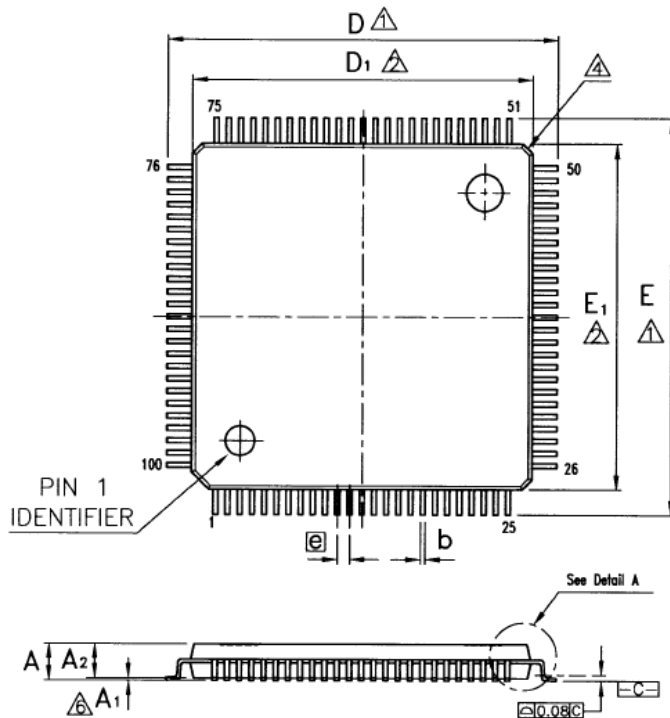

DETAIL A

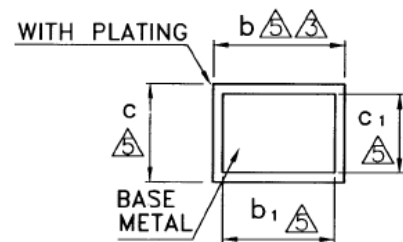

SECTION B-B

NOTE :

- △ TO BE DETERMINED AT SEATING PLANE $\square C$.
- △ DIMENSIONS D1 AND E1 DO NOT INCLUDE MOLD PROTRUSION. D1 AND E1 ARE MAXIMUM PLASTIC BODY SIZE DIMENSIONS INCLUDING MOLD MISMATCH.
- △ DIMENSION b DOES NOT INCLUDE DAMBAR PROTRUSION. DAMBAR CAN NOT BE LOCATED ON THE LOWER RADIUS OF THE FOOT.
- △ EXACT SHAPE OF EACH CORNER IS OPTIONAL.
- △ THESE DIMENSIONS APPLY TO THE FLAT SECTION OF THE LEAD BETWEEN 0.10 mm AND 0.25 mm FROM THE LEAD TIP.
- △ A1 IS DEFINED AS THE DISTANCE FROM THE SEATING PLANE TO THE LOWEST POINT OF THE PACKAGE BODY.
- 7. CONTROLLING DIMENSION : MILLIMETER.
- 8. REFERENCE DOCUMENT : JEDEC MS-026 , BED.

Symbol	Dimension in mm			Dimension in inch		
	Min	Nom	Max	Min	Nom	Max
A	—	—	1.60	—	—	0.063
A ₁	0.05	—	0.15	0.002	—	0.006
A ₂	1.35	1.40	1.45	0.053	0.055	0.057
b	0.17	0.22	0.27	0.007	0.009	0.011
b ₁	0.17	0.20	0.23	0.007	0.008	0.009
c	0.09	—	0.20	0.004	—	0.008
c ₁	0.09	—	0.16	0.004	—	0.006
D	15.85	16.00	16.15	0.624	0.630	0.636
D ₁	13.90	14.00	14.10	0.547	0.551	0.555
E	15.85	16.00	16.15	0.624	0.630	0.636
E ₁	13.90	14.00	14.10	0.547	0.551	0.555
e	0.50 BSC			0.020 BSC		
L	0.45	0.60	0.75	0.018	0.024	0.030
L ₁	1.00 REF			0.039 REF		
R ₁	0.08	—	—	0.003	—	—
R ₂	0.08	—	0.20	0.003	—	0.008
S	0.20	—	—	0.008	—	—
θ	0°	3.5°	7°	0°	3.5°	7°
θ ₁	0°	—	—	0°	—	—
θ ₂	12°TYP			12°TYP		
θ ₃	12°TYP			12°TYP		

9. Ordering Information

Part Number	Package	Status
RTS5130-GR	LQFP 100-pin Green package	Sample

Realtek Semiconductor Corp.

Headquarters

1F, No. 2, Innovation Road II, Hsinchu Science Park,
Hsinchu 300, Taiwan.

Tel: 886-3-5780211 Fax: 886-3-5776047

www.realtek.com.tw